

The block for June is taken from About.com:quilting. It is a mason "bug" jar. The jar fabric is anything that might possibly go in a jar—buttons, coins, fruits, veggies, etc. Use your imagination. Please read all directions carefully. The BOM Committee is supplying the jar lid fabric which is coated ironing board fabric. A little goes a long way as each strip will make *at least 4* blocks. **Background fabric is white-on-white.** There are 2 sizes

for the blocks and we are encouraging you to make both sizes to submit for the drawing. (Please follow these directions and **not** the ones on the website. These directions have been simplified.)

Cutting directions: **Large Jar**

Background (white-on-white)

1-2" x 6 1/2"-top

2-1" x 8"-sides

2-1 3/4" squares

2-1" x 1 1/2" rectangle-lid

Jar

1-5 1/2" x 7 1/2"

Lid

1-1"x 3 1/2"

1. With right sides facing, place a 1 3/4" square on the top corners of the jar fabric. Draw a diagonal line on the background fabric and sew on the line. Trim 1/4" from the line; flip the fabric to the right side and press. *See illustration*

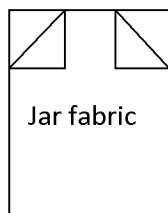

← trim here 1/4" from sewing line

2. Attach a 1 x 2" background square to each side of the lid fabric. Press to the lid fabric.

3. Attach the lid piece to the jar piece. Press the lid seam toward the lid.

4. Sew the 1" x 8" strips to either side of the jar. Press the strips toward the jar.

5. Sew the 2" x 6 1/2" background piece to the top of the jar and press toward the lid. Finished block size-6 1/2" x 9 1/2"

(OVER)

Cutting directions: **Small Jar**

Background (white-on-white)

1-4" x 5"-top

2-1" x 6"-sides

2-1 ½" squares

2-1" x 1 ½"-lid

Jar

1-4" X 5 1/2"

Lid

1-1"x 2 1/2"

1. With right sides facing, place a 1 ½" square on the top corners of the jar fabric. Draw a diagonal line on the background fabric and sew on the line. Trim ¼" from the line; flip the fabric to the right side and press. *See illustration*

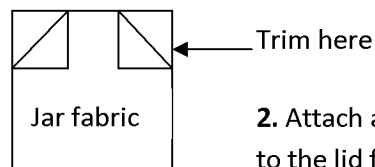

2. Attach a 1" x 1 ½" background piece to each side of the lid fabric. Press to the lid fabric.

3. Attach the lid piece to the jar piece. Press the lid seam toward the lid.

4. Sew the 1" x 6" strips to either side of the jar. Press the strips toward the jar.

5. Sew the 4" x 5 ½" background piece to the top of the jar and press toward the lid. Finished block size-5 x 9 ½"

Any Questions?

Debbie Brandenburg-708-672-7708

Julie Olczak-708-672-9649

Chris Arpin-708-877-2412

May Block of the Month
Pattern: Wild Thing from Thimble Blossoms

Fabrics-1-10" x 5" piece of white-on-white background--provided by Guild
2-5" x 5" squares of yellow (the predominant color must be **YELLOW**)

Step 1 Cut the background fabric in half to measure 2-5" x 5" squares. Place the background fabric squares on top of each other, **right sides up**. Place the squares on the rotary mat with the left-hand upper corner at the 1" mark. Place your ruler at a point just to the left of the 3" mark at the top and just to the right of the 3" mark at the bottom. **See illustration**. Cut the fabric on the diagonal using your ruler as a guide. Repeat this process with the yellow squares. **Remember: right sides up when stacked!!!!** You will have 4 squares cut into 8 pieces.

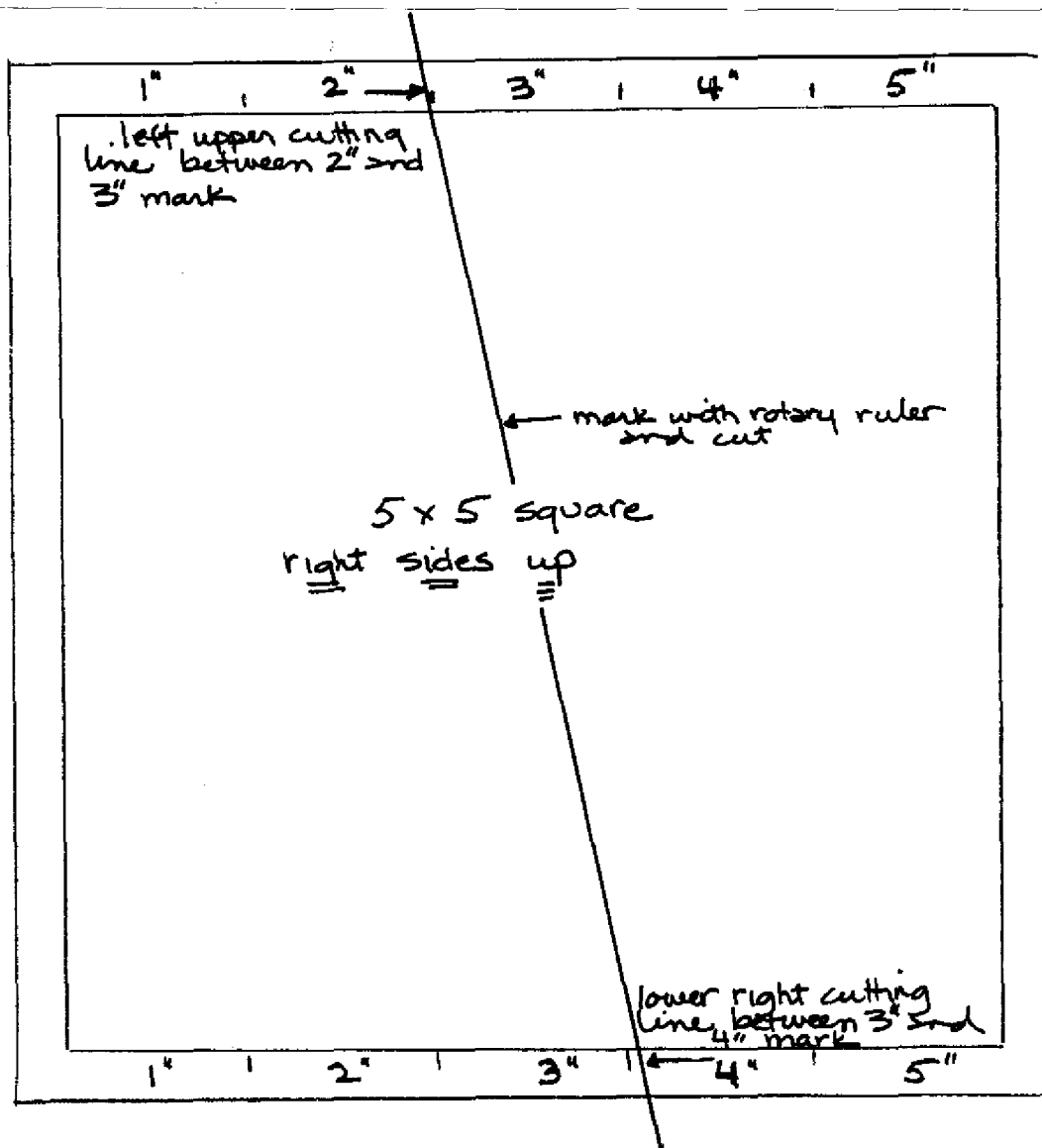

Step 2 Lay out the squares, right sides up, so that the left side is the background and the right side is the yellow fabric.

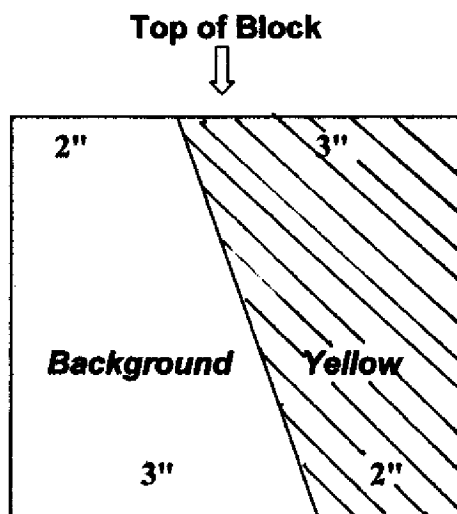

Flip the yellow piece onto the background (right sides together) with the right top of the yellow fabric a scant $\frac{1}{4}$ " above the background. Sew along the raw edge using a $\frac{1}{4}$ " seam. Press the seams open to help alleviate some of the bulk. Repeat the process with the remaining 3 pairs so that you have 4 identical blocks.

Step 3 Trim off the top of each block so that they measure $4\frac{1}{2}$ " x $4\frac{1}{2}$ ". See illustration above to locate top of block.

Step 4 Lay blocks as shown and sew with a $\frac{1}{4}$ " seam. Press. Block will measure $8\frac{1}{2}$ ".

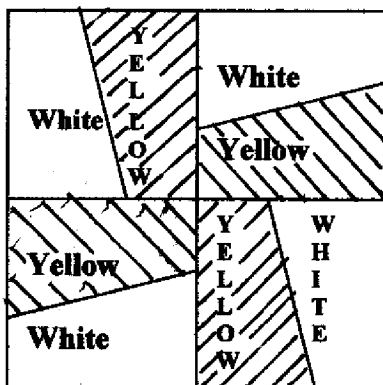

Questions?

Debbie Brandenburg
672-7708

Julie Olzak
672-9649

HERITAGE QUILTERS GUILD OF SOUTH SUBURBIA
BLOCK OF THE MONTH: **DUE APRIL 21, 2009**

READ ALL THE DIRECTIONS, PLEASE.

The block of the month is located at www.quilterscache.com. It is called NOSEGAY.
If you get your pattern from the website, be sure you measure/check the 1" test square!

The guild is providing fabric for the cone and base of the nosegay. Please call Debbie Brandenburg at 708-672-7708 if you need the fabric. The fabric is at Joann: Flower Patch by M'Liss Rae Hawley.

SUPPLIES:

- 1 10" square of cone fabric (provided by guild.)
- 1 5" square of base of cone fabric (provided by guild.)
- 1 10" square of background fabric white or white on white.
- 1 5" square of background fabric white or white on white.
- 16 2 1/2" by 2 1/2" squares of different flowered fabric

DIRECTIONS:

Block should measure 12 1/2 unfinished.

Stack, right sides together the 5" squares, TRIM to 4 7/8, draw diagonal, sew together using a scant 1/4" seam, trim away excess and press to the dark side. You will use only 1 of these half squares.

Stack, right sides together the 10" squares. Cut the squares into rectangles measuring 5 x 10". Trace each of the paper piecing rectangles onto your foundation paper. NOTE opposite diagonals, color coding and numbering. When trimmed, you should have 2 rectangles measuring approximately 4.5 x 8.5 that are 1/2 cone fabric and 1/2 background. NOTE: it does not work to try to cut triangles to make the rectangular cone...there might be a method but the paper pieced way is the easiest.*

**See page 2 to use traditional piecing of rectangle for cone.*

- BG 1 = Background fabric white or white on white
- Cone 2 = Fabric provided by guild

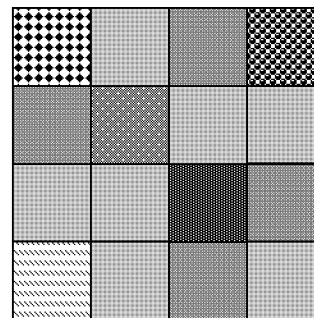

Assemble 16 2 1/2" squares of flowered fabric into a 4 x 4 block.

Sew one rectangle to the base.

Sew the other rectangle to the 16 flowered blocks and
Then sew that to the rectangle and base.
Block should measure 12 1/2 unfinished.

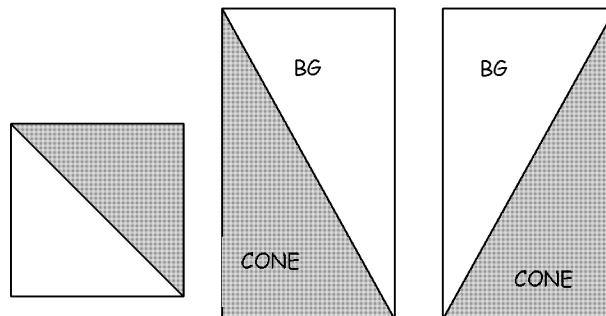

Problems?

Chris 708-877-2412

Debbie 708-672-7708

Julie 708-672-9649

NOSEGAY RECTANGLE CUTTING AND ASSEMBLY

FROM DARK FABRIC CUT 2 PIECES 5" X 9". PLACE WRONG SIDES TOGETHER. CUT DIAGONALLY CORNER TO CORNER.

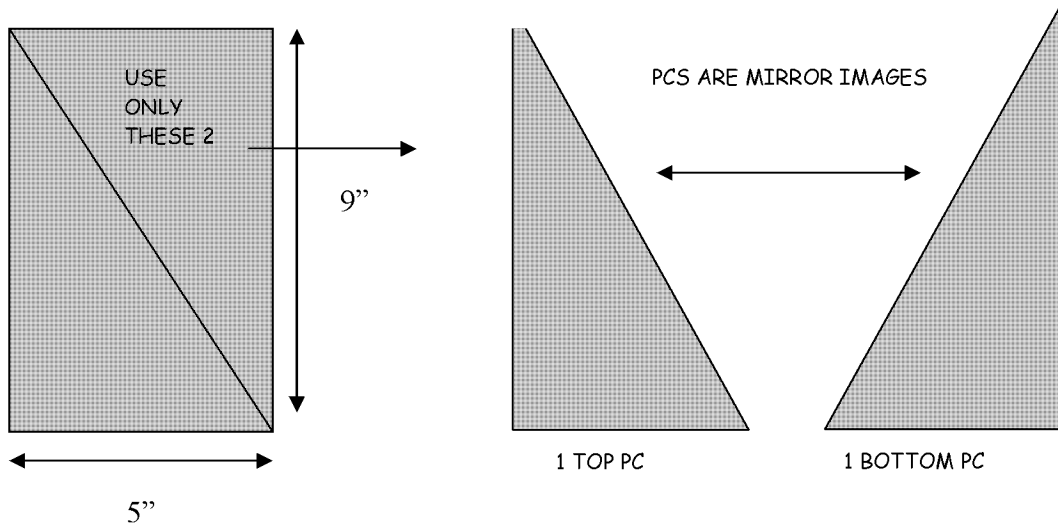

FROM WHITE FABRIC CUT 2 PIECES 5" X 9". PLACE WRONG SIDES TOGETHER. CUT DIAGONALLY CORNER TO CORNER

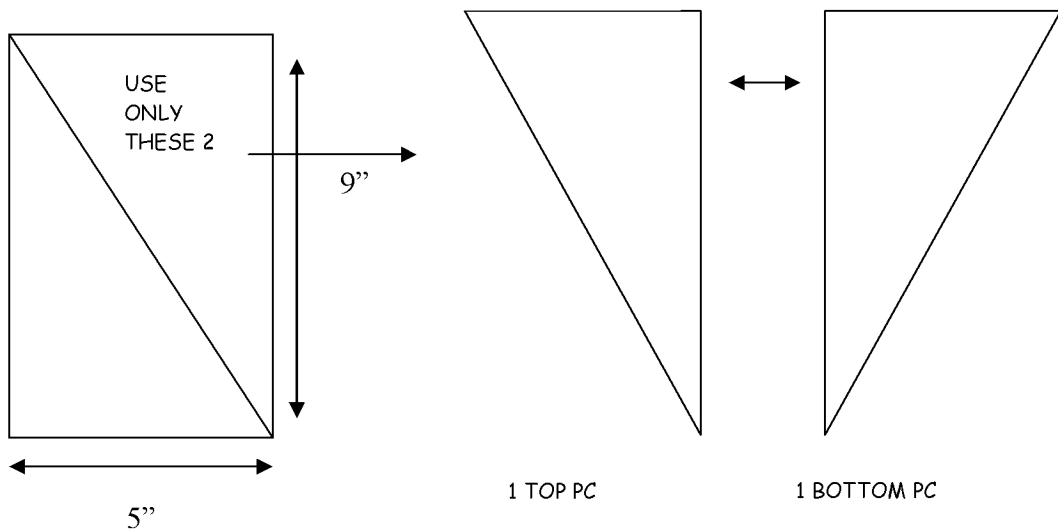

INTERSECTION

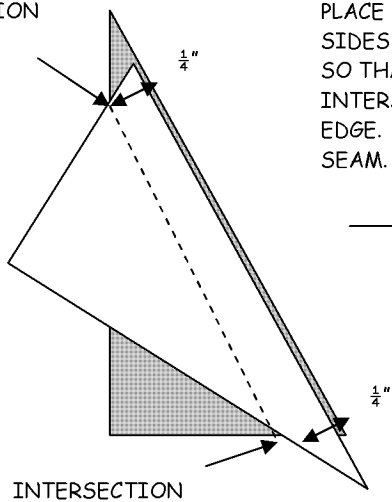

PLACE PIECES RIGHT SIDES TOGETHER SO THAT THEY INTERSECT $\frac{1}{4}"$ FROM EDGE. SEW $\frac{1}{4}"$ SEAM.

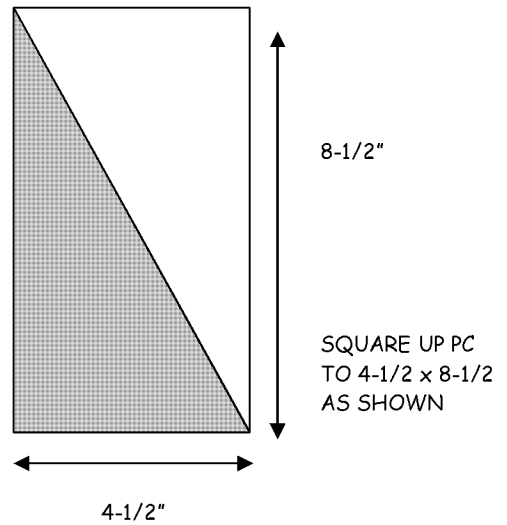

NOSEGAY

Here's another opportunity for you to use up some scraps! It makes a 12" Block, and is partly paper pieced!

Please abide by the [Terms and Conditions of use!](#) :o)

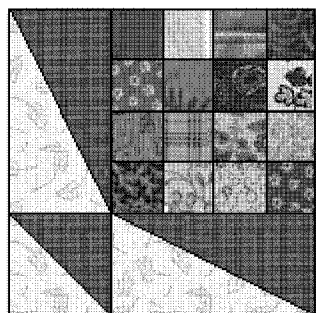

** Preparing the Pieces and Sewing the Block **

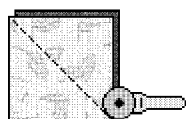

Stack and diagonally bisect your Color 1 and Color 2 4-7/8" squares...



Sew them together, using a scant 1/4" seam, and pressing the seam allowances towards the darker fabric...you will only need ONE of these half squares...

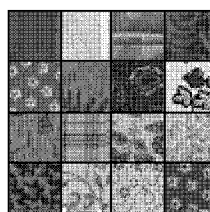
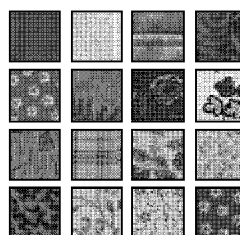

Now join your 16 2-1/2" squares as shown. Press seams in opposite directions by row. Now we are ready to put it all together!

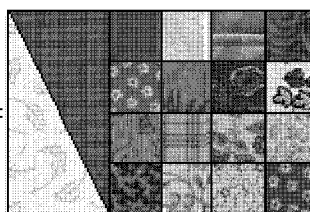
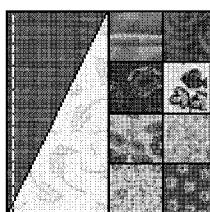

We start by sewing one of the paper pieced rectangles to the left side of the "posies" (the square made of squares!) This makes row one of the block...

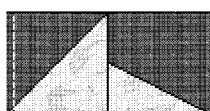

Then to make row two sew the half square to the left end of the other rectangle unit, as shown...on to [Page 2!](#)

©Sept1999 Marcia Hohn

its an mh paper

Traditional Block

pattern from
<http://www.quilterscache.com>

Nosegay - Page 2

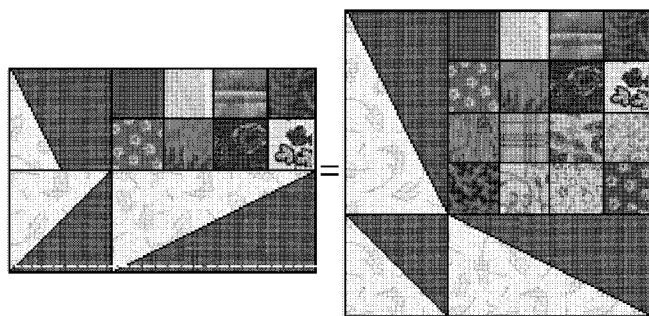

Then sew row two on the bottom of row one!! TA DA!! Finis! :o)

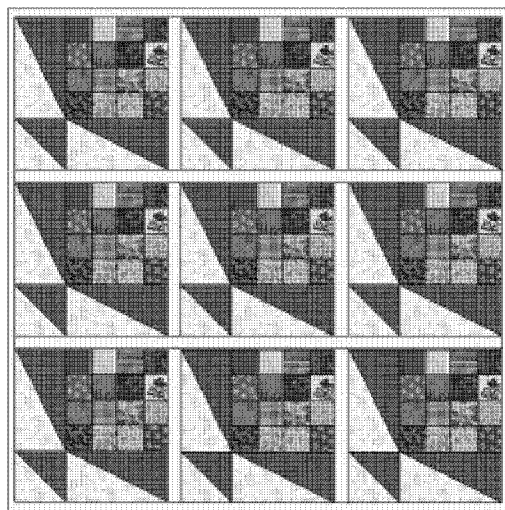

I really think I like this one sewn together using some borders between the blocks!

Happy Quilting!...Marcia :o)

Page 1

Here's one that Karen made!

and Dessa's! Marisa's! Vera's!

and here's the Needle Nellie's! Elizabeth's!

**** Supplies List ****



Color 1 Color 1 needs: one 4-7/8" square AND one 10" square



Color 2 Color 2 needs: one 4-7/8" square AND one 10" square



Calicoes Calicoes need: 16 2-1/2" squares in a variety of colors and prints

To the Patterns or The Quilter's Cache

©Sept1999 Marcia Hohn

its an mh paper

Traditional Block

pattern from
<http://www.quilterscache.com>

DUCK TRACKS

DARK BLUE- CUT (2) 3" X 3" SQUARES

WHITE - CUT (2) 3" X 3" SQUARES

(ON WRONG SIDE DRAW A LINE DIAGONONALY *CORNER TO CORNER* ON (2) PIECES)

WHITE - CUT (8) 2-1/2" X 2-1/2" SQUARES

(ON WRONG SIDE DRAW A LINE DIAGONALLY *CORNER TO CORNER* ON (4) PIECES)

MEDIUM BLUE - CUT (2) 2-1/2" X 4-1/2" RECTANGLES

MEDIUM BLUE - CUT (2) 2-1/2" X 4-1/2" RECTANGLES

1. STACK EACH OF 2 WHITE 3" X 3" WHITE SQS. ON A DARK BLUE 3" X 3" SQ. SEW $\frac{1}{4}$ " TO EITHER SIDE OF DIAGONAL LINE. CUT ON LINE, PRESS TO DARK, SQUARE UP TO 2-1/2" X 2-1/2". THIS WILL MAKE (4) HALF SQUARE TRIANGLES.
2. SEW ONE WHITE 2-1/2" SQUARE TO THE DARK BLUE SIDE OF THE HALF SQUARE TRIANGLE MADE IN STEP ONE WITH THE WHITE TRIANGLE ON THE LOWER RIGHT. (SEE FIGURE 1) MAKE (4).
3. PLACE A WHITE 2-1/2" X 2-1/2" SQ ON THE SHORT SIDE OF THE MEDIUM BLUE RECTANGLE WITH THE DRAWN DIAGONAL LINE ON THE UPPER RIGHT CORNER. SEW ON DIAGONAL LINE. FLIP UP TO MAKE SURE SEWED PIECE IS SQUARE THEN TRIM SEAM ALLOWANCE TO $\frac{1}{4}$ INCH, PRESS TO WHITE. (SEE FIGURE 2) MAKE (4).
4. SEW HALF-SQ TRIANGLE WITH WHITE SQUARE TO MEDIUM BLUE RECTANGLE HAVING DARK BLUE TRIANGLE AJACENT TO MEDIUM BLUE WITH WHITE TRIANGLES ON THE UPPER LEFT SIDE AND LOWER RIGHT SIDE . (SEE FIGURE 3) MAKE 4 SETS.
5. ASSEMBLE AS SHOWN IN FIGURE 4.

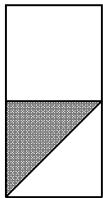

FIG. 1

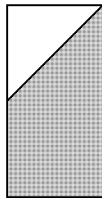

FIG. 2

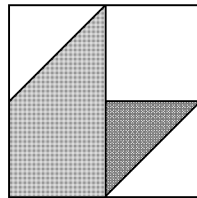

FIG. 3

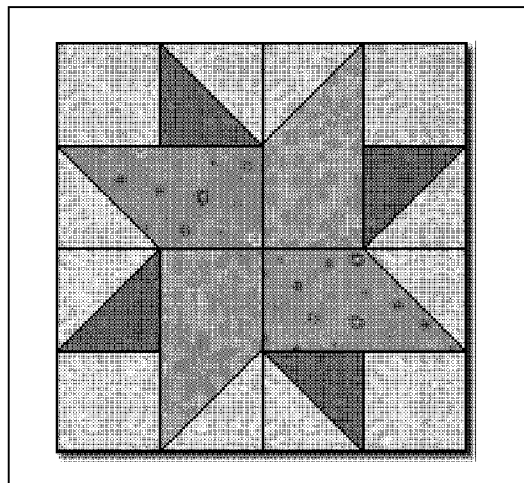
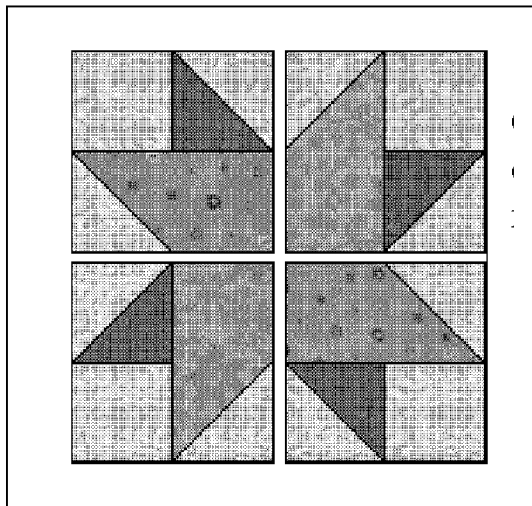

FIG. 4

RAGGED HEARTS

NOVEMBER BOM
DUE TUESDAY JANUARY 20, 2009

Homespun Quilts
Anna Laura Reidt
4102 E. Hartson, Ave.
Spokane, WA 99202
509-535-8494

FABRIC REQUIREMENTS:

- Cut 1 8 ½” by 8 ½” square of light background (white, cream, tone on tone)
- Assorted scraps (7” x 7” and smaller) of red prints with brown (shades of red, pink, burgundy with brown: dark to light)
- Use a taupe or khaki colored thread since the colors are deep reds, pink.

DIRECTIONS:

Trace the 3 different sized heart patterns (printed on the back of this sheet) onto freezer paper. Iron onto selected fabric: use varying darks and light for contrast.

Fold the 8 ½ “x 8 ½” in half and half again. Crease lightly, open and place the largest heart right side up in the center, using the creases to help center. It doesn’t have to be perfect.

Sew the heart to the background, right sides up, about ¼” from the edge. Turn the square over and carefully trim the background fabric out of the center of the heart , about ¼’ from the stitching line to reduce some of the bulk.

Turn the block back to the right side and center the middle size heart on top of the large one. Repeat the above steps. Sew around the edge of the middle size heart, ¼” in from the edge, turn over and trim out the center of the large heart, ¼” from the stitching line.

Turn the block to the right side and center the small heart in the center and stitch around the edge as before. You do not need to trim the underside this time.

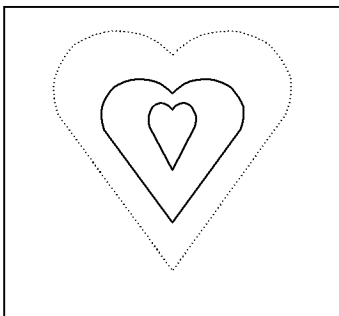

Heart Patterns

3 sizes

Trace all three patterns onto template plastic (each size heart on a different template). Cut out on outside lines for each size. The center broken lines are for placement only. Do not cut on the broken lines. **Do not cut out this paper pattern**, there are directions on the reverse side.

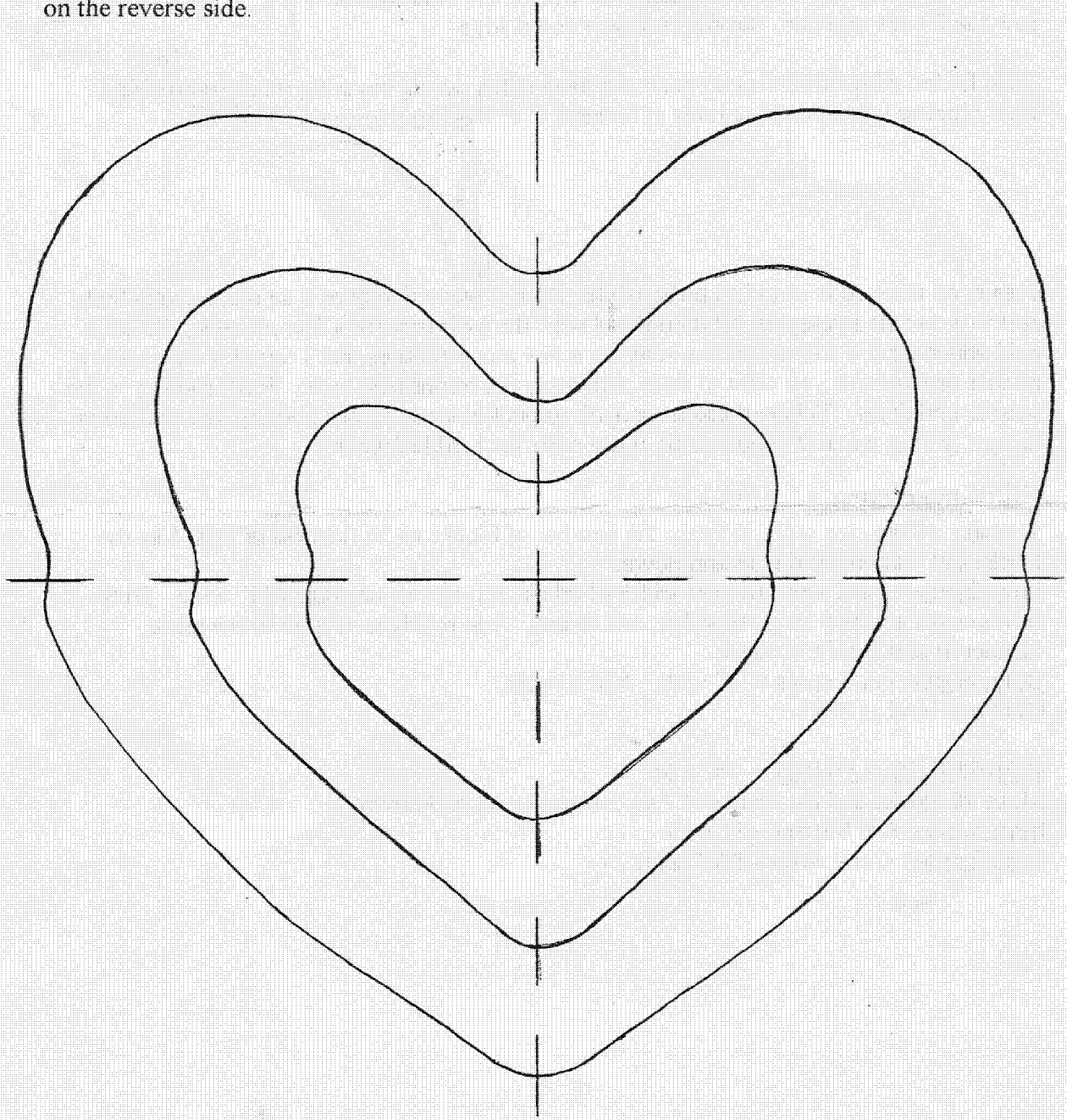

October 2008
Block of the Month
Due November 18

CHRISTMAS STOCKING QUILT BLOCK 10 1/2" by 8 1/2" unfinished

By Janet Wickell, quilting.about.com

Fabric Requirements: (white → tone on tone, Christmas reds, greens or blacks)
3 - 1 3/4" squares of **white tone on tone** for 3 corners of the boot (background)
1 - 4" x 7" rectangle of background
1 - 4" square for boot
1 - 5" x 8" rectangle for boot
1 - 3" x 5" stocking trim

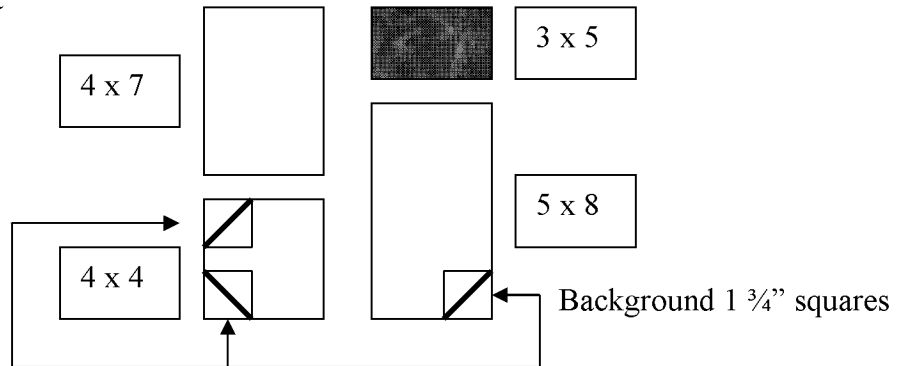

Add snowball tips to 4 x 4 square and lower right corner of boot using 1 3/4" squares

Snowball directions:

Take the 3 - 1 3/4" background squares and draw a diagonal line on the backside of each one. Align 2 of the small background squares in 2 corners on the 4" x 4" fabric and 1 of the small background squares in the lower right corner of the 5" x 8" fabric rectangle. Stitch along the diagonal line. Press upper triangle down, lift and trim excess background and boot corner; re-press the upper triangle down to form the lower corner of the front and rear of the boot.

Assemble the block:

- 1) Sew the snowball 4 x 4" square to the 4 x 7" background rectangle
- 2) Sew the 5 x 8" rectangle to the 3 x 5" stocking trim piece
- 3) Sew the 2 units together
- 4) Block should measure 10 1/2 by 8 1/2 inches
- 5) Press seam allowances away from light background fabric

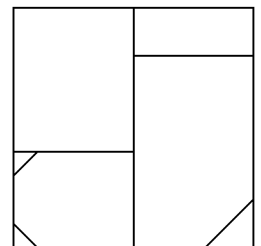

Suggestions:

Make a mirror image by sewing 1 3/4" squares to the opposite side of the 4x4" square; then move the other vertical pieces to opposite positions.

Questions? Complaints? Comments?

Chris Arpin 708-877-2412

Debbie Brandenburg 708-672-7708

Julie Olczak 708-672-9649

DANCING STARS
September 2008 BLOCK of the MONTH

SUPPLIES:

- 5 2 1/2" x 11" different strips in FALL COLORS
- 1 Rectangle 4 1/2" by 9 1/2" (provided by the guild w/diagonal line on back)

DIRECTIONS:

Block Fabric: Figure A

Sew the 5 strips together using 1/4" seam allowance.

Square the strips to 10 1/2" by 10 1/2". (Figure A)

Press seams open...this will reduce bulk when star centers are joined.

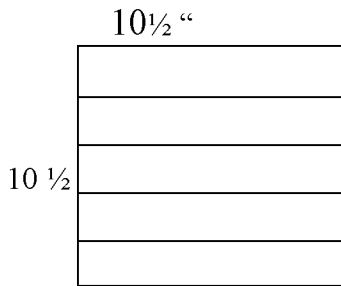
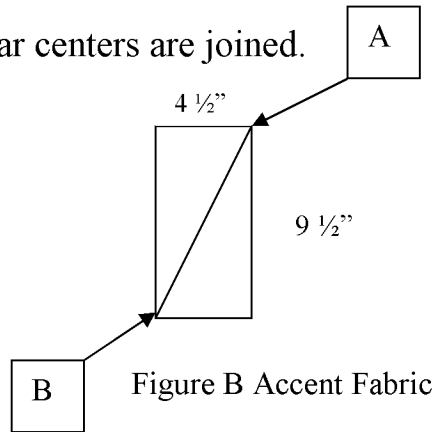

Figure A



Accent Fabric: Figure B

Place the 10 1/2 by 10 1/2 square face up with seams horizontal. (Figure A)

Place the 4 1/2 x 9 1/2 rectangle provided by the guild (Figure B) on top of block with the diagonal line facing up....ie ...right sides together!

Place one diagonal point on the 3rd seam (point A) and place the opposite diagonal point (point B) on bottom edge of the block. (Figure C)

**** LAST STEP!!! ****

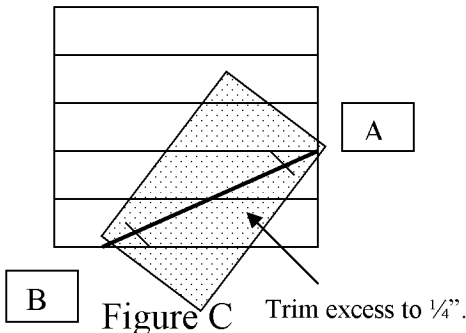

Pin the diagonal line in place. (Points A and B)
Sew a thread or 2 below the diagonal line.
 Fold the rectangle over the diagonal stitching and press. Open and trim excess rectangle and block fabric below to 1/4". Press rectangle down to form lower right hand corner of block.
 Trim again to 10 1/2 by 10 1/2.

Questions?
 Chris Arpin 708-877-2412
 Debbie Brandenburg 708-672-7708
 Julie Olczak 708-672-9649

adapted from Cozy Quilt Designs
 2940 Jamacha Rd. Suite H
 El Cajon, CA 92019
 619-670-0652
www.cozydesigns.com
 see full pattern for sizes /star ideas

**Make as many blocks as you wish for drawing but please take and use only 1 rectangle.
 Turn in extra blocks without any rectangle on them.
 The winner(s) will receive extra fabric to complete stars that do not have the rectangle on them.**